



Carr. 869, Calle 4 Las Palmas Industrial Park, Cataño, Puerto Rico 00962

Tel. 787-641-2420

## Sterling Two Door Wine Merchandiser



**Model: SGW2-54**

### Technical Data

Width	53 1/8 Inches
Depth	31 7/8 Inches
Height	83 7/8 Inches
Power Cord Length	98 1/2 Inches
Interior Width	50 Inches
Left Door Opening Width	22 7/8 Inches
Right Door Opening Width	22 7/8 Inches
Interior Depth	28 3/8 Inches
Interior Height	62 1/2 Inches
Amps	6 Amps
Hertz	60 Hz

### Features

- Crisp LED lighting offers clear visibility of your best bottles of wine
- Chrome curved racks securely hold and effectively merchandise bottles
- Self-closing, anti-fog swing glass door
- Precise temperature settings between 35 and 65 degrees Fahrenheit for white, red, or sparkling wines
- Uses R-290 refrigerant; 115V

### Dimensions

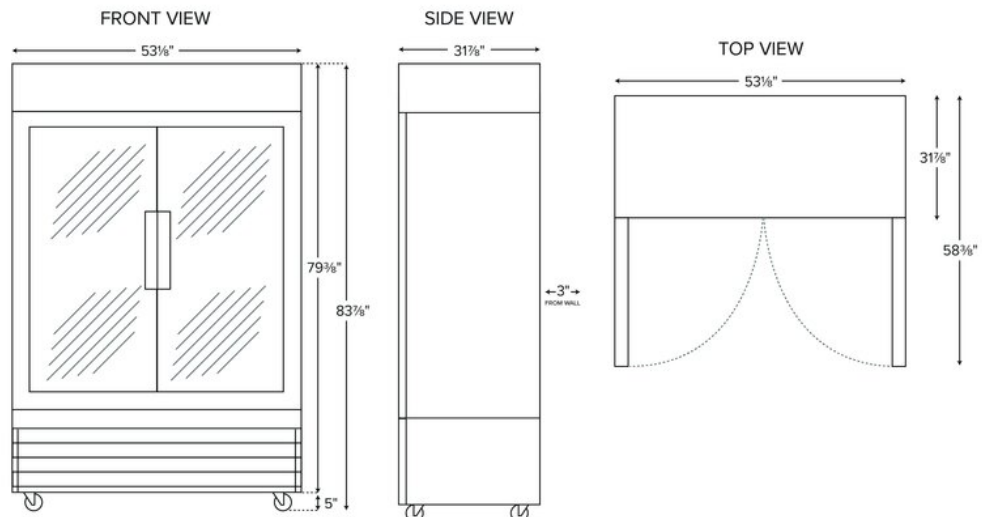

## Technical Data

Phase	1 Phase
Voltage	115 Volts
Wattage	576 Watts
Access Type	Doors
BTU (LBP)	1365 BTU
Capacity	32 Bottles 40 cu. ft.
Casters	With Casters
Color	Black
Compressor Location	Bottom Mounted
Door Style	Swing
Door Type	Glass
Exterior Finish	Black
Features	Customizable LED Lighting Lighted Interior Self-Closing Doors
Glass Style	Flat
Hinge Location	Left Right
Horsepower	1/4 HP
Individual Shelf Capacity	90 lb.
Installation Type	Freestanding
Interior Color	Black
Number of Doors	2 Doors
Number of Shelves	10 Shelves
Refrigerant Capacity	3.5 oz.
Refrigerant Type	R-290
Sections	2 Section
Service Type	Self Service
Starting Amps	18 Amps
Starting Wattage	1728 Watts
Temperature	35 - 65 Degrees F
Range Type	Merchandisers Wine Refrigerator

## Certifications



**OLDACH**  
REFRIGERATION, AIR CONDITIONING & VENTILATION SUPPLIER

[www.sterlingprofessionalpr.com](http://www.sterlingprofessionalpr.com)

