



Carr. 869, Calle 4 Las Palmas Industrial Park, Cataño, Puerto Rico 00962

Tel. 787-641-2420

Sterling SUC2-60R Undercounter Refrigerator

Model: SUC2-60R



Technical Data

Width	60 1/4 Inches
Depth	29 1/2 Inches
Height	35 1/4 Inches
Power Cord Length	84 Inches
Interior Width	55 5/8 Inches
Left Door Opening Width	25 11/16 Inches
Right Door Opening Width	25 11/16 Inches
Interior Depth	22 7/8 Inches
Interior Height	23 1/2 Inches
Work Surface Height	35 1/4 Inches

Features

- Strong and sleek 430 type stainless steel exterior
- 304 type stainless steel interior maintains temperatures from 33 to 40 degrees Fahrenheit
- Foamed-in-place polyurethane insulation
- Easy-to-read digital temperature controller and auto-defrost function
- 115V; 1/3 hp; 1.33 Amps

Dimensions

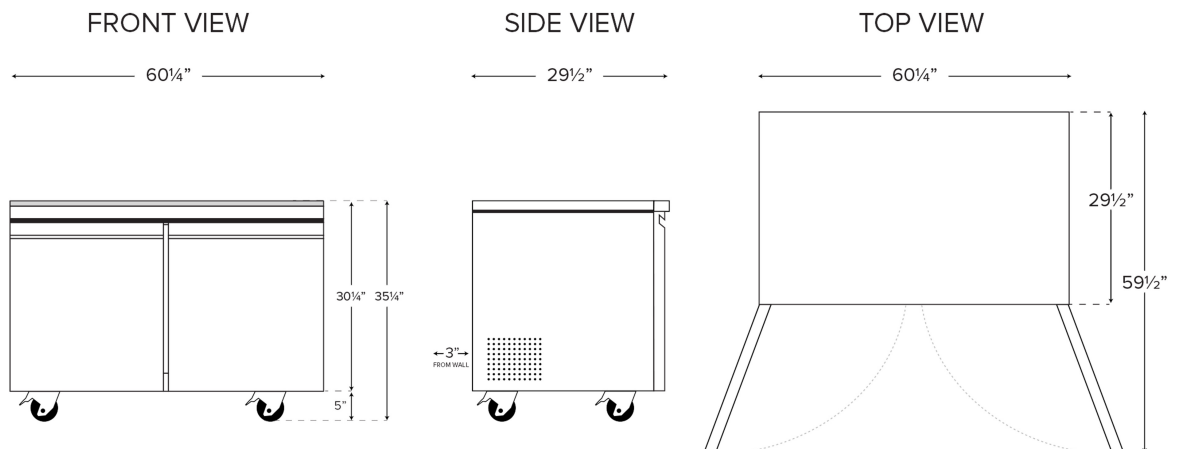

Technical Data

Amps	1.33 Amps
Hertz	60 Hertz
Phase	1 Phase
Voltage	115 Volts
Access Type	Doors
BTU (LBP)	881 BTU
Capacity	14.2 cu. ft.
Compressor Location	Rear Mounted
Compressor Style	Side / Rear Breathing
Door Style	Swing
Door Type	Solid
Features	Self-Closing Doors
Hinge Location	Left/Right
Horsepower	1/3 HP
Individual Shelf Capacity	88 lb.
Number of Doors	2 Doors
Number of Shelves	2 Shelves
Plug Type	NEMA 5-15P
Refrigerant Capacity	3.5 oz.
Refrigerant Type	R-290
Style	Counter Height
Temperature Range	33 - 40 Degrees F
Top Capacity	441 lb.
Type	Refrigerators Undercounter Refrigerators

Certifications



ETL Sanitation



ETL, US



5-15P

OLDACH
REFRIGERATION, AIR CONDITIONING & VENTILATION SUPPLIER

www.sterlingprofessionalpr.com

