



Carr. 869, Calle 4 Las Palmas Industrial Park, Cataño, Puerto Rico 00962

Tel. 787-641-2420

## Sterling SUC2-48R Undercounter Refrigerator

**Model: SUC2-48R**

### Technical Data



Width	47 1/4 Inches
Depth	29 1/2 Inches
Height	35 1/4 Inches
Power Cord Length	84 Inches
Interior Width	42 1/2 Inches
Left Door Opening Width	19 3/16 Inches
Right Door Opening Width	19 3/16 Inches
Interior Depth	22 7/8 Inches
Interior Height	23 1/2 Inches
Work Surface Height	35 1/4 Inches

### Features

- Strong and sleek 430 type stainless steel exterior
- 304 type stainless steel interior maintains temperatures from 33 to 40 degrees Fahrenheit
- Foamed-in-place polyurethane insulation
- Easy-to-read digital temperature controller and auto-defrost function
- 115V; 1/3 hp; 1.33 Amps

### Dimensions

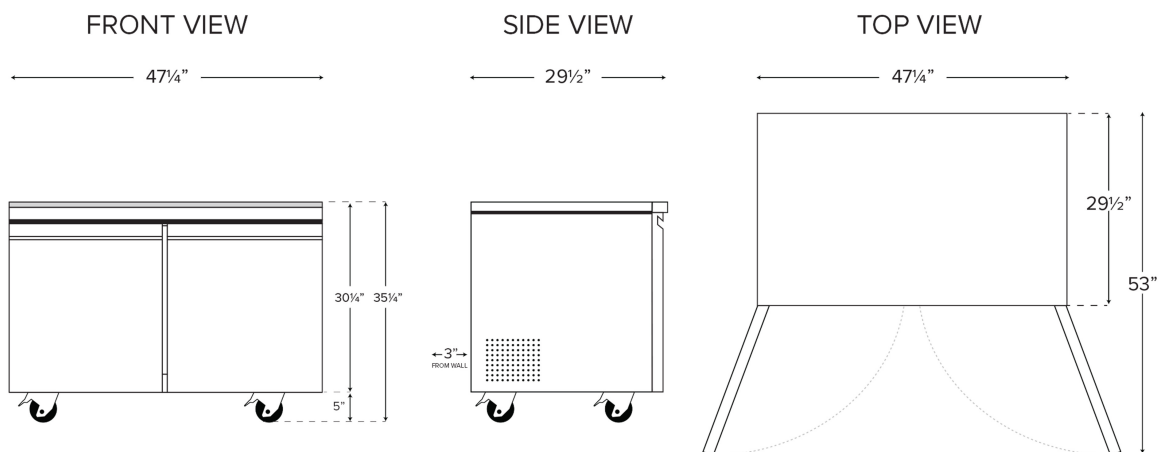

## Technical Data

Amps	1.33 Amps
Hertz	60 Hertz
Phase	1 Phase
Voltage	115 Volts
Access Type	Doors
BTU (LBP)	881 BTU
Capacity	11.2 cu. ft.
Compressor Location	Rear Mounted
Compressor Style	Side / Rear Breathing
Door Style	Swing
Door Type	Solid
Features	Self-Closing Doors
Hinge Location	Left/Right
Horsepower	1/3 HP
Individual Shelf Capacity	88 lb.
Number of Doors	2 Doors
Number of Shelves	2 Shelves
Plug Type	NEMA 5-15P
Refrigerant Capacity	3.5 oz.
Refrigerant Type	R-290
Style	Counter Height
Temperature Range	33 - 40 Degrees F
Top Capacity	441 lb.
Type	Refrigerators Undercounter Refrigerators

## Certifications



5-15P



ETL, US



ETL Sanitation

**OLDACH**  
REFRIGERATION, AIR CONDITIONING & VENTILATION SUPPLIER

[www.sterlingprofessionalpr.com](http://www.sterlingprofessionalpr.com)

