



Carr. 869, Calle 4 Las Palmas Industrial Park, Cataño, Puerto Rico 00962

Tel. 787-641-2420

## Sterling SSU2-60-24M 2 Door Mega Top Stainless Steel Refrigerated Sandwich Prep Table

**Model: SSU2-60-24M**



### Technical Data

Width	60 1/4 Inches
Depth	35 Inches
Height	45 7/8 Inches
Power Cord Length	84 Inches
Cutting Board Width	60 1/4 Inches
Interior Width	56 1/4 Inches
Left Door Opening Width	26 1/16 Inches
Nominal Width	60 Inches
Right Door Opening Width	26 1/16 Inches
Cutting Board Depth	8 Inches

### Features

- Mega top accommodates (24) 1/6 size, 6" deep food pans
- Industry-best 3/4" cutting board is built-in for convenient prep space and removable for cleaning
- Digital control with auto defrost
- Stainless steel exterior and interior; foamed-in-place polyurethane insulation
- 115V; 1/2 hp compressor; R290 refrigerant; 2.4 Amps

### Dimensions

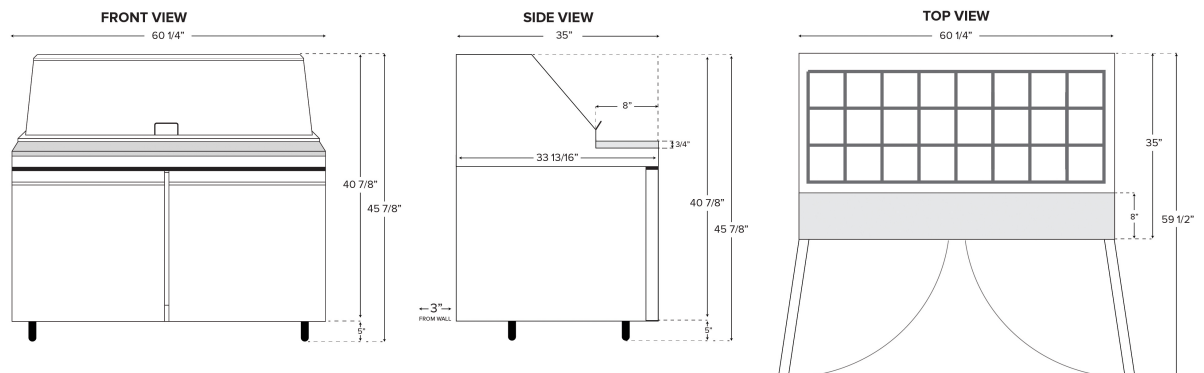

## Technical Data

Interior Depth	23 3/4 Inches
Height with Lid Open	51 5/8 Inches
Interior Height	23 1/2 Inches
Work Surface Height	35 1/4 Inches
Amps	2.4 Amps
Hertz	60 Hertz
Phase	1 Phase
Voltage	115 Volts
1/6 Size Pan Capacity	24 Pans
Access Type	Doors
BTU (LBP)	1285 BTU
Capacity	15 cu. ft.
Casters	With Casters
Compressor Location	Rear Mounted
Compressor Style	Side / Rear Breathing
Construction	Stainless Steel
Door Style	Swing
Door Type	Solid
Hinge Location	Left/Right
Horsepower	1/2 HP
Individual Shelf Capacity	88 lb.
Number of Doors	2 Doors
Number of Shelves	2 Shelves
Plug Type	NEMA 5-15P
Refrigerant Capacity	4.6 oz.
Refrigerant Type	R-290
Refrigeration Type	Air Cooled
Style	Counter Height
Temperature Range	33 - 40 Degrees F
Top Type	Mega Top

## Certifications



5-15P



ETL, US & Canada



ETL Sanitation

**OLDACH**  
REFRIGERATION, AIR CONDITIONING & VENTILATION SUPPLIER

[www.sterlingprofessionalpr.com](http://www.sterlingprofessionalpr.com)

