



Carr. 869, Calle 4 Las Palmas Industrial Park, Cataño, Puerto Rico 00962

Tel. 787-641-2420

Sterling SPT2-67 Two Door Refrigerated Pizza Prep Table

Model: SPT2-67



Technical Data

Width	67 15/16 Inches
Depth	37 1/8 Inches
Height	42 13/16 Inches
Power Cord Length	98 1/2 Inches
Cutting Board Width	67 15/16 Inches
Interior Width	47 5/8 Inches
Left Door Opening Width	14 3/16 Inches
Nominal Width	68 Inches
Packaging Width	73 1/16 Inches
Right Door Opening Width	22 1/16 Inches

Features

- Top rail accommodates (8) 1/3 size, 6" deep food pans
- Cutting board built-in for convenient prep space
- Maintains temperatures between 33 and 40 degrees Fahrenheit
- Stainless steel exterior and interior; foamed-in-place polyurethane insulation
- R290 refrigerant; 115V; 2/5 hp; 2.63 Amps

Dimensions

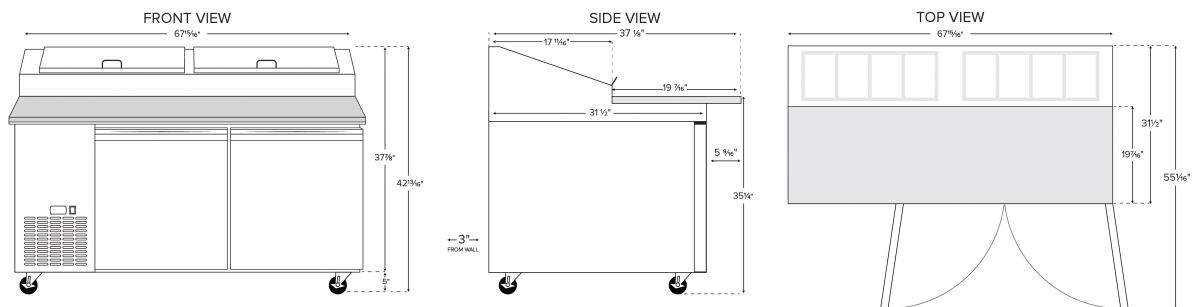

Technical Data

Depth (with cutting board)	37 1/8 Inches
Interior Depth	26 3/16 Inches
Packaging Depth	36 5/8 Inches
Shelf Depth	24 3/8 Inches
Cutting Board Height	3/4 Inches
Height with Lid Open	56 5/8 Inches
Interior Height	22 7/8 Inches
Packaging Height	45 7/8 Inches
Work Surface Height	35 1/4 Inches
Amps	2.63 Amps
Hertz	60 Hertz
Voltage	115 Volts
1/3 Size Pan Capacity	8 Pans
Access Type	Doors
BTU (LBP)	1285 BTU
Capacity	16.3 cu. ft.
Compressor Style	Side / Rear Breathing
Construction	Stainless Steel
Door Style	Swing
Door Type	Solid
Features	Automatic Electric Defrost Digital Temperature Controller
Horsepower	2/5 HP
Individual Shelf Capacity	88 lb.
Insulation Material	Polyurethane Foam
Material	Stainless Steel
Maximum Ambient Temperature	90 Degrees F
Net Weight	419 lb.
Number of Doors	2 Doors
Number of Shelves	2 Shelves
Plug Type	NEMA 5-15P
Refrigerant Capacity	3.9 oz.
Refrigerant Type	R-290
Refrigeration Type	Air Cooled
Shelf Material	Epoxy-Coated Steel
Temperature Range	33 - 40 Degrees F
Top Capacity	353 lb.

Certifications



ETL Sanitation



ETL, US & Canada



5-15P

OLDACH
REFRIGERATION, AIR CONDITIONING & VENTILATION SUPPLIER

www.sterlingprofessionalpr.com

