



Carr. 869, Calle 4 Las Palmas Industrial Park, Cataño, Puerto Rico 00962

Tel. 787-641-2420

## Sterling SPT1-44 Door Refrigerated Pizza Prep Table

**Model: SPT1-44**



### Technical Data

Height	42 13/16 Inches
Power Cord Length	98 1/2 Inches
Cutting Board Width	44 1/2 Inches
Interior Width	22 1/4 Inches
Nominal Width	44 Inches
Packaging Width	49 3/4 Inches
Right Door Opening Width	22 1/16 Inches
Shelf Width	21 1/2 Inches
Cutting Board Depth	19 7/16 Inches
Depth (with cutting board)	37 1/8 Inches

### Features

- Top rail accommodates (5) 1/3 size, 6" deep food pans
- Cutting board built-in for convenient prep space
- Maintains temperatures between 33 and 40 degrees Fahrenheit
- Stainless steel exterior and interior; foamed-in-place polyurethane insulation
- R290 refrigerant; 115V; 1/3 hp; 1.88 Amps

### Dimensions

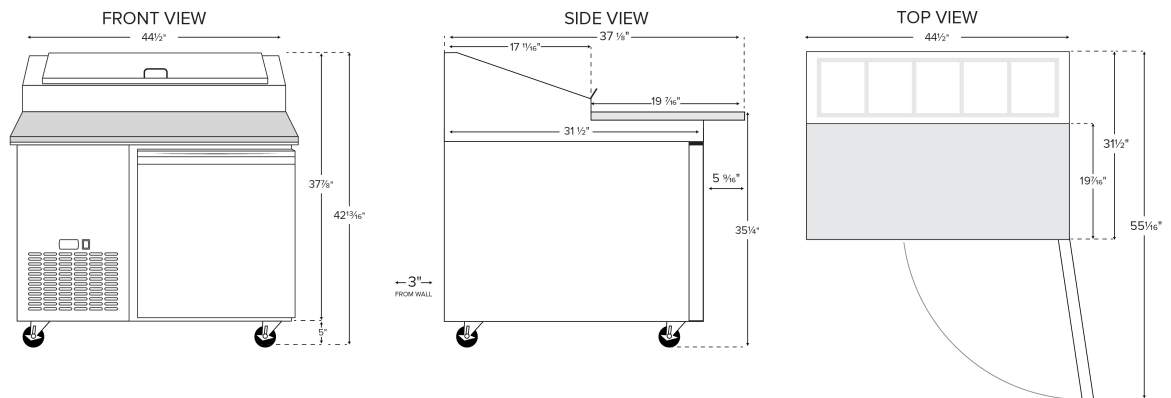

## Technical Data

Interior Depth	26 3/16 Inches
Packaging Depth	36 5/8 Inches
Shelf Depth	24 3/8 Inches
Cutting Board Height	3/4 Inches
Height with Lid Open	56 5/8 Inches
Interior Height	22 7/8 Inches
Packaging Height	45 7/8 Inches
Work Surface Height	35 1/4 Inches
Amps	1.88 Amps
Hertz	60 Hertz
Voltage	115 Volts
1/3 Size Pan Capacity	5 Pans
Access Type	Doors
BTU (LBP)	786 BTU
Capacity	7.6 cu. ft.
Compressor Style	Side / Rear Breathing
Construction	Stainless Steel
Door Style	Swing
Door Type	Solid
Features	Automatic Electric Defrost Digital Temperature Controller
Horsepower	1/3 HP
Individual Shelf Capacity	88 lb.
Insulation Material	Polyurethane Foam
Material	Stainless Steel
Maximum Ambient Temperature	90 Degrees F
Net Weight	287 lb.
Number of Doors	1 Doors
Number of Shelves	1 Shelf
Plug Type	NEMA 5-15P
Refrigerant Capacity	3.5 oz.
Refrigerant Type	R-290
Refrigeration Type	Air Cooled
Shelf Material	Epoxy-Coated Steel
Temperature Range	33 - 40 Degrees F
Top Capacity	353 lb.

## Certifications



ETL Sanitation



ETL, US & Canada



5-15P

**OLDACH**  
REFRIGERATION, AIR CONDITIONING & VENTILATION SUPPLIER

[www.sterlingprofessionalpr.com](http://www.sterlingprofessionalpr.com)

