



Carr. 869, Calle 4 Las Palmas Industrial Park, Cataño, Puerto Rico 00962

Tel. 787-641-2420

## Sterling SGD2-54R Black Swing Glass Door Merchandiser Refrigerator with LED Lighting



**Model: SGD2-54R**

### Technical Data

Width	53 1/8 Inches
Depth	31 7/8 Inches
Height	83 7/8 Inches
Power Cord Length	96 Inches
Interior Width	50 Inches
Left Door Opening Width	22 7/8 Inches
Right Door Opening Width	22 7/8 Inches
Interior Depth	28 3/8 Inches
Interior Height	61 7/8 Inches
Amps	3.14 Amps

### Features

- Features (2) self-closing, anti-fog, dual-pane tempered glass swing doors with magnetic gaskets
- Interior LED lighting illuminates product; back-lit exterior top panel attracts customers' attention
- 8 adjustable shelves with price tag strip on each shelf
- Easy-to-use digital temperature controls
- 115V, 1/2 hp compressor; R290 refrigerant; 3.14 amps

### Dimensions

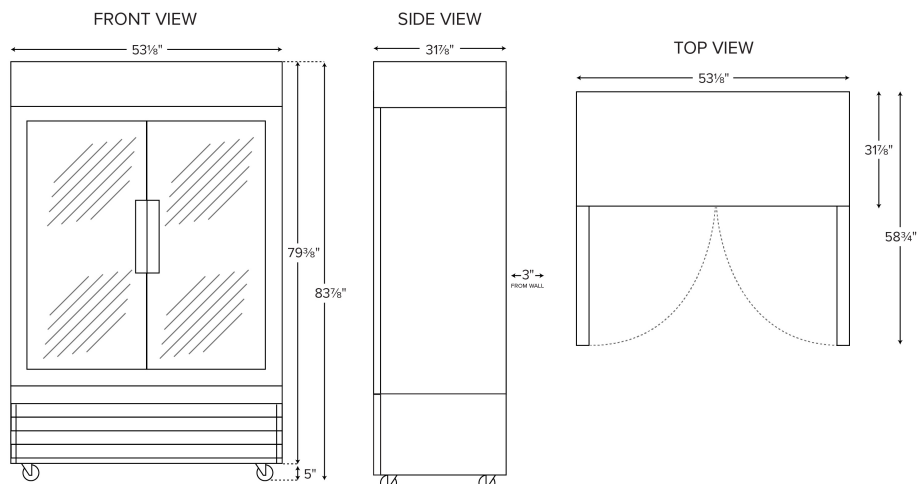

## Technical Data

Phase	1 Phase
Voltage	115 Volts
Access Type	Doors
BTU (LBP)	1285 BTU
Capacity	42.5 cu. ft.
Color	Black
Compressor Location	Bottom Mounted
Door Style	Swing
Door Type	Glass
Features	Customizable LED Lighting
Hinge Location	Left/Right
Horsepower	1/2 HP
Individual Shelf Capacity	90 lb.
Installation Type	Freestanding
Interior Color	White
Number of Doors	2 Doors
Number of Shelves	8 Shelves
Plug Type	NEMA 5-15P
Refrigerant Capacity	3.5 oz.
Refrigerant Type	R-290
Sections	2 Sections
Temperature Range	33 - 40 Degrees F
Type	Merchandising Refrigeration

## Notes & Details

Increase your sales of "grab and go" items like bottled tea and soda, or pre-packaged sandwiches and salads with this Avantco GDC-49-HC 53" black merchandising refrigerator! Designed with sharp looks and usability in mind, this unit is the perfect display for your products with its sleek black finish and a lighted top graphics area. And, since the housing is made from black-coated steel, you can be sure that it will provide superior durability. Additionally, it boasts 2 anti-fogging, dual-pane tempered glass swing doors to ensure that customers always have a clear view of your products, while 8 epoxy-coated steel shelves help you stay organized. Each shelf can hold up to 90 lb. of product. Plus, the shelves easily adjust to accommodate changing inventory and menus. Interior LED lighting on the right side also works to illuminate and further merchandise your products.

Designed to maintain temperatures from 33-40 degrees Fahrenheit, this refrigerator boasts a bottom-mounted 1/2 hp compressor that runs on R290 refrigerant. This specialized refrigerant has an ozone depletion potential (ODP) of 0 and a global warming potential (GWP) of 3. In addition, the bottom-mounted design makes it easy for employees to load and unload products due to the raised bottom shelf. For optimal temperature retention, the entire cabinet is foamed in place using polyurethane insulation. Other helpful features include self-closing aided by magnetic gaskets, automatic defrosting, and a digital temperature control. This item requires a 115V electrical connection for operation.

**⚠ WARNING:** This product can expose you to chemicals including lead, which are known to the State of California to cause cancer, birth defects, or other reproductive harm. For more information, go to [www.p65warnings.ca.gov](http://www.p65warnings.ca.gov).

## Certifications



**OLDACH**  
REFRIGERATION, AIR CONDITIONING & VENTILATION SUPPLIER



[www.sterlingprofessionalpr.com](http://www.sterlingprofessionalpr.com)