



Carr. 869, Calle 4 Las Palmas Industrial Park, Cataño, Puerto Rico 00962

Tel. 787-641-2420

## Sterling SGD2- 54F Black Swing Glass Door Merchandiser Freezer with LED Lighting



**Model: SGD2-54F**

### Technical Data

Width	53 1/8 Inches
Depth	31 7/8 Inches
Height	83 7/8 Inches
Power Cord Length	96 Inches
Interior Width	47 7/16 Inches
Left Door Opening Width	21 11/16 Inches
Right Door Opening Width	21 11/16 Inches
Interior Depth	26 15/16 Inches
Interior Height	58 11/16 Inches
Caster Diameter	4 Inches

### Features

- 2 self-closing, anti-fog dual-pane tempered glass swing doors with magnetic gaskets
- Easy-to-use digital temperature controls, temperature range: -7 - 0
- Includes 4 adjustable, plastic-coated steel shelves
- Interior LED lighting; 4" casters included
- 115V, 1 1/2 hp, R290 refrigerant

### Dimensions

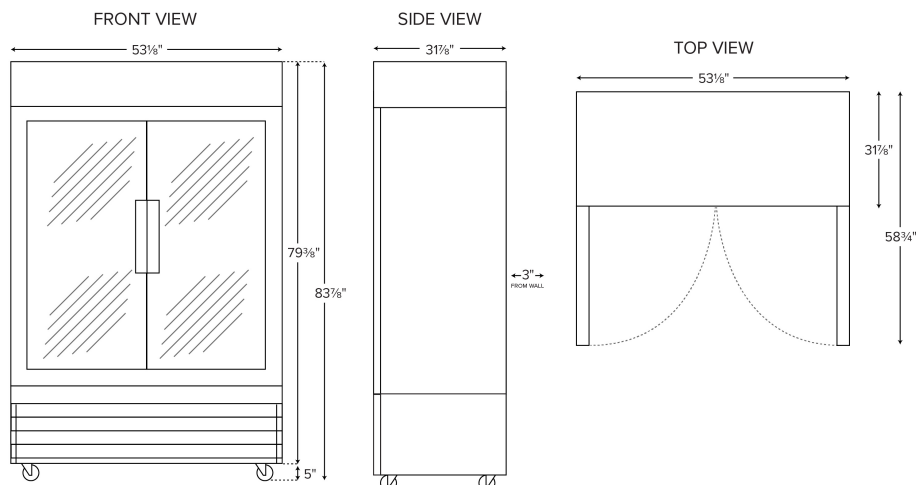

## Technical Data

Amps	6.97 Amps
Hertz	60 Hertz
Phase	1 Phase
Voltage	115 Volts
Access Type	Doors
BTU (LBP)	3720 BTU
Capacity	37.08 cu. ft.
Casters	With Casters
Color	Black
Compressor Location	Bottom Mounted
Door Style	Swing
Door Type	Glass
Features	Customizable LED Lighting Lighted Interior Self-Closing Doors
Horsepower	1 1/2 HP
Individual Shelf Capacity	90 lb.
Interior Color	White
Number of Doors	2 Doors
Number of Shelves	8 Shelves
Plug Type	NEMA 5-15P
Refrigerant Capacity	4.9 oz.
Refrigerant Type	R-290
Sections	2 Sections
Temperature Range	-7 - -0 Degrees F
Type	Merchandising Refrigeration

## Notes & Details

Increase impulse sales of frozen meals, novelty treats, fruits, and vegetables with this Avantco GDC-24F-HC 31 1/8" black merchandising freezer! Designed with sharp looks and usability in mind, this unit is the perfect display for your products with its sleek finish. And, since the housing is made from black coated steel, you can be sure that it will provide superior durability. This unit boasts an anti-fogging, dual-pane tempered glass swing door to ensure that customers always have a clear view of your products, while 4 epoxy coated steel shelves help you stay organized. Plus, the shelves easily adjust to accommodate prepackaged foods in a variety of sizes. Interior LED lighting also works to illuminate and further merchandise your products.

Designed to maintain temperatures from -8 to -1 degree Fahrenheit, this freezer boasts a bottom-mounted 1 hp compressor that runs on R290 refrigerant. This specialized refrigerant has an ozone depletion potential (ODP) of 0 and a global warming potential (GWP) of 3. In addition, the bottom-mounted design makes it easy for employees to load and unload products due to the raised bottom shelf. For optimal temperature retention, the entire cabinet is foamed-in place using polyurethane insulation. Other helpful features include self-closing aided by magnetic gaskets, automatic defrosting, as well as a digital temperature control and display. This item requires a 115V electrical connection for operation.

**WARNING:** This product can expose you to chemicals including lead, which are known to the State of California to cause cancer, birth defects, or other reproductive harm. For more information, go to [www.p65warnings.ca.gov](http://www.p65warnings.ca.gov).

## Certifications



5-15P



Customizable



ETL, US

**OLDACH**  
REFRIGERATION, AIR CONDITIONING & VENTILATION SUPPLIER



[www.sterlingprofessionalpr.com](http://www.sterlingprofessionalpr.com)