



Carr. 869, Calle 4 Las Palmas Industrial Park, Cataño, Puerto Rico 00962

Tel. 787-641-2420

## Sterling SGD1-29R Black Swing Glass Door Merchandiser Refrigerator with LED Lighting



**Model: SGD1-29R**

### Technical Data

Width	28 3/8 Inches
Depth	31 7/8 Inches
Height	83 7/8 Inches
Power Cord Length	96 Inches
Interior Width	25 1/4 Inches
Left Door Opening Width	25 1/4 Inches
Interior Depth	28 3/8 Inches
Interior Height	62 1/2 Inches
Amps	1.33 Amps
Hertz	60 Hertz

### Features

- Features (1) self-closing, anti-fog dual-pane tempered glass swing door with magnetic gaskets
- Interior LED lighting illuminates product; back lit exterior top panel attracts customers' attention
- 4 adjustable shelves with price tag strip on each shelf
- Easy to use digital temperature controls
- 115V; 1/3 hp; R290 refrigerant; 1.33 Amps

### Dimensions

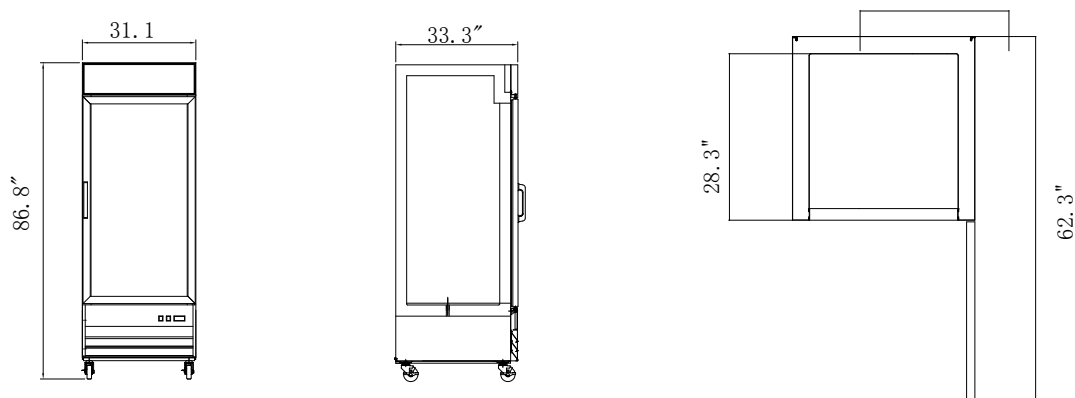

## Technical Data

Phase	1 Phase
Voltage	115 Volts
Access Type	Doors
BTU (LBP)	881 BTU
Capacity	23 cu. ft.
Color	Black
Compressor Location	Bottom Mounted
Door Style	Swing
Door Type	Glass
Features	Customizable LED Lighting
Hinge Location	Right
Horsepower	1/3 HP
Individual Shelf Capacity	90 lb.
Installation Type	Freestanding
Interior Color	White
Number of Doors	1 Doors
Number of Shelves	4 Shelves
Plug Type	NEMA 5-15P
Refrigerant Capacity	2.6 oz.
Refrigerant Type	R-290
Sections	1 Section
Temperature Range	33 - 40 Degrees F
Type	Merchandising Refrigeration

## Notes & Details

Increase your sales of "grab and go" items like bottled tea and soda, or pre-packaged sandwiches and salads with this

Sterling SGD1-29R black merchandising refrigerator! Designed with sharp looks and usability in mind, this unit is the perfect display for your products with its sleek finish. And, since the housing is made from black coated steel, you can be sure that it will provide superior durability. This unit boasts an anti-fogging, dual-pane tempered glass swing door to ensure that customers always have a clear view of your products, while (4) epoxy coated steel shelves help you stay organized. Plus, the shelves easily adjust to accommodate salads, wraps, or sandwiches. Interior LED lighting also works to illuminate and further merchandise your products.

Designed to maintain temperatures from 33-40 degrees Fahrenheit, this refrigerator boasts a bottom-mounted 1/3 hp compressor that runs on R290 refrigerant. This specialized refrigerant has an ozone depletion potential (ODP) of 0 and a global warming potential (GWP) of 3. In addition, the bottom-mounted design makes it easy for employees to load and unload products due to the raised bottom shelf. For optimal temperature retention, the entire cabinet is foamed-in place using polyurethane insulation. Other helpful features include self-closing aided by magnetic gaskets, automatic defrosting, as well as a digital temperature control and display. This item requires a 115V electrical connection for operation.

## Certifications



**WARNING:** This product can expose you to chemicals including lead, which are known to the State of California to cause cancer, birth defects, or other reproductive harm. For more information, go to [www.p65warnings.ca.gov](http://www.p65warnings.ca.gov).

**OLDACH**  
REFRIGERATION, AIR CONDITIONING & VENTILATION SUPPLIER

**STERLING**  
PROFESSIONAL

[www.sterlingprofessionalpr.com](http://www.sterlingprofessionalpr.com)